

Swissloop Tunneling - Press Kit EN

2022 - 2023

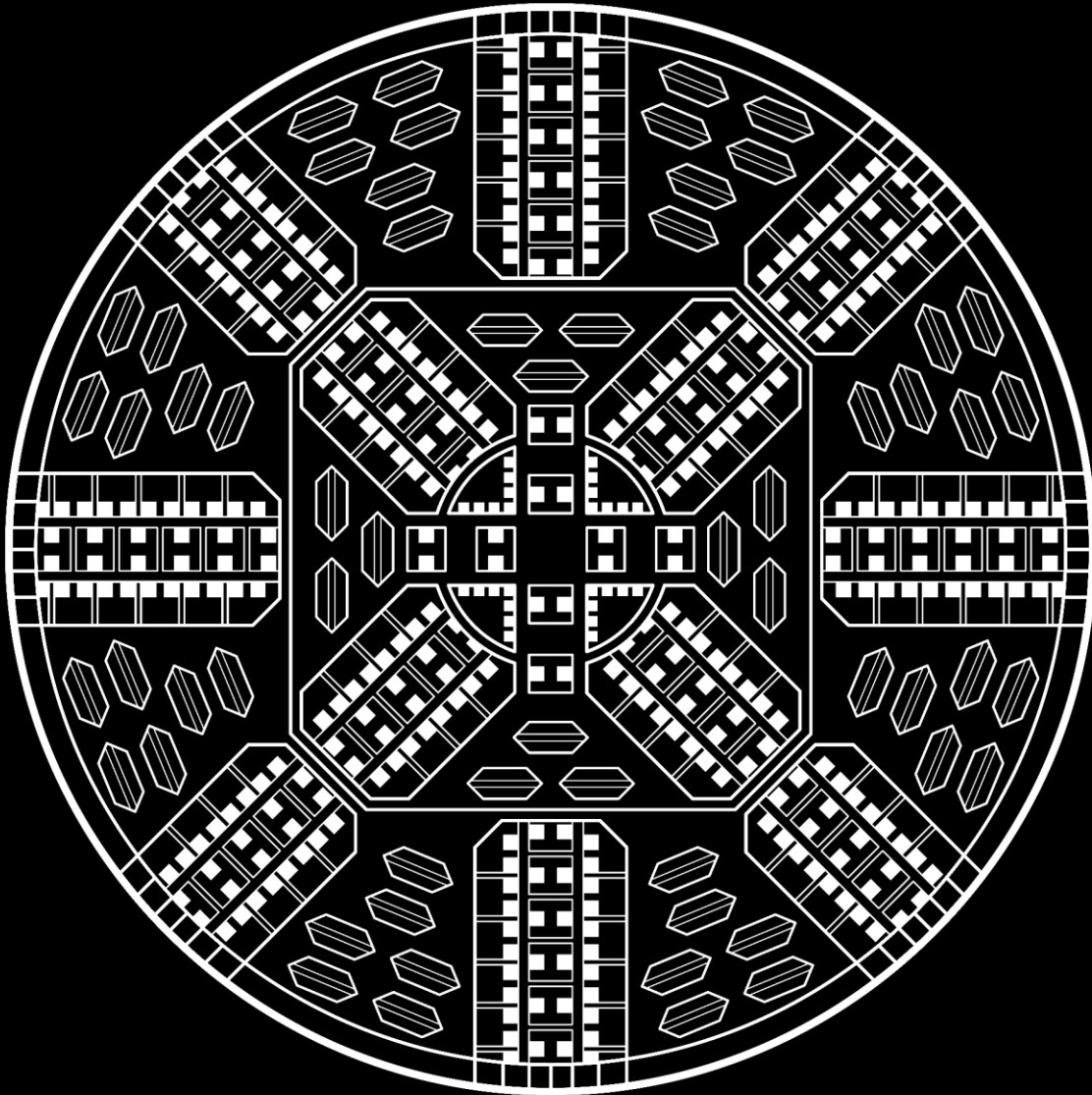

Not-A-Boring-Competition 2023

The competition challenges teams to develop new solutions for tunnel construction and to be faster than a snail can slither. *"The Boring Company"* has invited 5 finalist teams from around the world to present their own tunneling solutions at the second Not-a-Boring-Competition from March 25th to April 2nd, 2023, in Bastrop, Texas, USA. Swissloop Tunneling won the Innovation & Design Award and also took second place in the overall competition. The winning categories included:

- Overall competition winner: 1st TUM Boring, 2nd Swissloop Tunneling
- Innovation award: Swissloop Tunneling
- Navigation system award: CU Hyperloop

In 2021, Swissloop Tunneling was able to place second and win the Innovation & Design Award at the first Not-a-Boring-Competition. Our Micro Tunnel Boring Machine (MTBM) machine, *Groundhog Beta*, features a new and improved liner mechanism and erosion mechanism compared to the first prototype, *Groundhog Alpha*.

Commercial Use Cases - Spinoff

After two and a half years after the founding of Swissloop Tunneling, a group of team members is working on the commercialization of our technology for micro tunneling applications. The spinoff, UNDER INDUSTRIES, is an independent company. Swissloop Tunneling will continue as an association and on a voluntary basis as before. A third Not-a-Boring-Competition has already been announced.

Project Description & Retrospect

Swissloop Tunneling is a student association from the Swiss Federal Institute of Technology (ETH) Zurich, the University of St. Gallen, and other Swiss universities researching new solutions in the tunneling industry. In 2021, the Swissloop Tunneling team designed and built its first MTBM, *Groundhog Alpha*, named after one of nature's most sophisticated tunneling animals, the groundhog. With a unique control mechanism and advanced tunnel lining system, *Groundhog Alpha* is more maneuverable than conventional solutions and capable of simultaneously 3D printing the tunnel wall during continuous digging. This novel solution offers corresponding advantages that have been lacking so far.

After being selected from over 400 applicants, Swissloop Tunneling was invited as part of the *"digging dozen"* - the twelve finalist teams - to present *Groundhog Alpha* at Elon Musk's Not-a-Boring-Competition from September 6th to 12th, 2021, in Las Vegas, Nevada, USA. *Groundhog Alpha* has been continuously developed since participating in the Not-a-

Boring-Competition. In 2022, a new machine was designed as an optimized version of the first prototype. *Groundhog Beta* retains all the functional strengths of the *Alpha* model while being significantly smarter and more efficient, especially in the navigation and tunnel lining mechanisms.

Modern Challenges in the Tunneling Industry

Some of the most significant problems in the tunneling industry nowadays are high costs and the challenging logistics processes involved. TBMs and lining parts are heavy and typically need to be transported hundreds of kilometers to the tunnel construction site. Additionally, conventional TBMs stay idle for longer periods during liner ring construction procedures. Under those circumstances, it is hard to imagine an efficient development of the Hyperloop concept by means of TBMs over long distances. The TBMs currently in use (which are required for road construction) are not standardized, and the costs related to the maintenance of long Hyperloop tunnels and networks are extremely high. Furthermore, pipe jacking – one of the most spread and used methods for micro tunneling - is not scalable to the required Hyperloop diameters (up to 4.4 meters). For those reasons, Swissloop Tunneling strives to develop small-scale TBMs with innovative manufacturing technology that can be scaled up to larger dimensions in the future.

Hyperloop Concept

Hyperloop is a new form of transportation that aims to overcome today's problems of conventional mobility. With Hyperloop as a futuristic transport concept, transportation vehicles would be accelerated to high speeds inside tunnel tubes by means of pressurized systems (i.e., vacuum). This enables the cost-effective and time-saving transportation of people and goods over long distances. Moreover, this technology is more sustainable, and with achieved speeds of over 1000km/h (600mph) in transportation, it is faster than current high-speed trains and airplanes.

Loop Concept

The Loop concept is an underground, fully electronic, and emission-free high-speed public transportation system that moves passengers to their destination without intermediate stops. The concept is also known as "Teslas in Loops" and is more similar to an underground highway than a subway system. The concept allows Loop vehicles to travel faster than conventional subway vehicles (up to 250km/h (150mph) vs. up to 100km/h (65mph)).

Vision

Updated on April 1st, 2023

Swissloop Tunneling's vision is to surpass the status quo of the tunnel construction industry and make tunneling more sustainable, cost-effective, and faster. To achieve this, Swissloop Tunneling conducts research on new and innovative tunnel boring mechanisms. *Groundhog Beta's* purpose is to increase our digging speed and optimize processes in a way that will significantly reduce tunnel construction costs in the future. This is also necessary to meet Hyperloop's infrastructure requirement, which would require hundreds of kilometers of tunnel routes.

Swissloop Tunneling's vision goes far beyond international competitions. The long-term vision for this project is to develop innovative (micro-)tunnel solutions through continuous optimization of technical systems and learning from the experiences gained during competitions. In the next few years, the Swissloop Tunneling team aims to increase the diameter of the prototypes and make the liner mechanism marketable. The spinoff *UNDER INDUSTRIES* is working on commercializing our tunnel construction technology.



Erosions- und Steuerungs-Subsystem transportiert mittels unserem 25t-Kran

Swissloop Tunneling Journey

Elon Musk organized four SpaceX-Hyperloop competitions, where students worldwide constructed prototype "pods" to transport people and goods as part of the Hyperloop concept. At the end of the SpaceX-Hyperloop Competition in 2019, Elon Musk announced that *The Boring Company* would conduct a tunnel boring competition in the future. This was officially communicated in the summer of 2020. As a result, four former members of Swissloop, the Swiss team that previously participated in the SpaceX-Hyperloop competitions, founded Swissloop Tunneling at ETH Zurich.

Today, this student initiative brings together over 70 students from mechanical engineering, electrical engineering, civil engineering, and several business disciplines. The team,

Updated on April 1st, 2023

comprised of members from ETH Zurich and other Swiss universities such as the University of St. Gallen (HSG), is proud to represent Switzerland as the only Swiss team in the final round of the Not-a-Boring-Competition, selected from over 400 applicants worldwide.

Groundhog Beta



In 2022, the Swissloop Tunneling team designed, built, and tested, further optimizing their MTBM from *Groundhog Alpha* to *Groundhog Beta*. Since the first model, *Groundhog Alpha*, Swissloop Tunneling has pursued a very innovative and ambitious approach. Swissloop Tunneling is convinced that this approach will form the basis for future tunnel boring solutions.

Specifications

- Length: 8.19 m
- Weight: 3.1 t
- Diameter: 0.606 m
- Propulsion forces: 200 kN
- Motor RPMs: 940 rpm
- Cutting Face RPMs: 12 rpm
- Target speed: 0.1 m/s

Erosion

The erosion system uses water jets with a foam conditioning agent inside a protective shield to erode fat clay. A rotating crusher handles larger paving stones and prepares them for the jet pump, which transports the debris out of the tunnel. After passing through a separation plant, the water can be reused. Groundhog Beta's erosion system is powered by a hydraulic motor. The previous model was driven by an electric motor. With a torque of 9.5 kNm, a rotation speed of 12 rpm, and a thrust force of 200 kN, Swissloop Tunneling is ready for any soil conditions that Groundhog Beta may encounter.

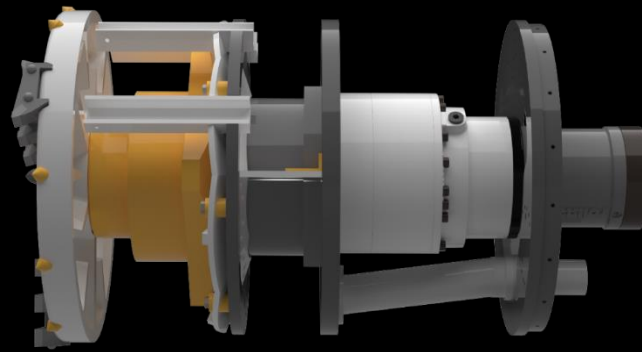

Steering

To dig curves, a hydraulic Stewart platform (referred to as a *hexapod*) was developed. The drilling head can be moved along the six spatial degrees of freedom thanks to the six accurate hydraulic cylinders composing the hexapod. With custom-designed software, it is possible to switch the machine into a so-called *jackhammer mode*, generating vibrations with frequencies up to 20 Hz. This also makes it possible to interrupt the erosion process and intervene promptly in case the cutting head gets stuck

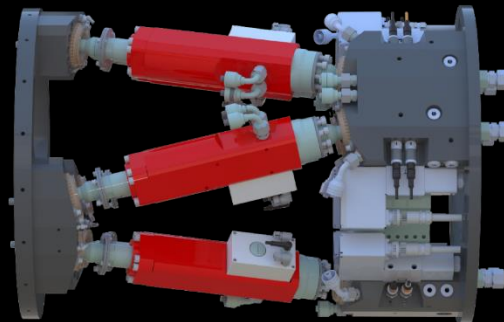

Liner

The tunnel lining is extruded in situ in the front part of the machine. The tunnel lining system consists of a pneumatic mechanism feeding polypropylene granulate into the machine. It gets melted by heating elements, injected into extrusion nozzles using a screw conveyor, and cooled down in its final pipe form. The polymer is designed to withstand the machine's propulsion forces and the surrounding earth pressure while digging. Groundhog Beta's tunnel lining system overcomes the difficulties of the former two-component system and represents a more environmentally friendly solution. The material used in the system is very similar to those used in conventional 3D printing applications, making it easier to manufacture and reuse for other applications. Additionally, polypropylene granulate can be transported in its solid state into the machine. The melting and

Updated on April 1st, 2023

cooling processes can be repeated indefinitely, allowing the machine to stay idle in case of unexpected issues. After cooling, the tunnel lining pipes are 15 mm thick.

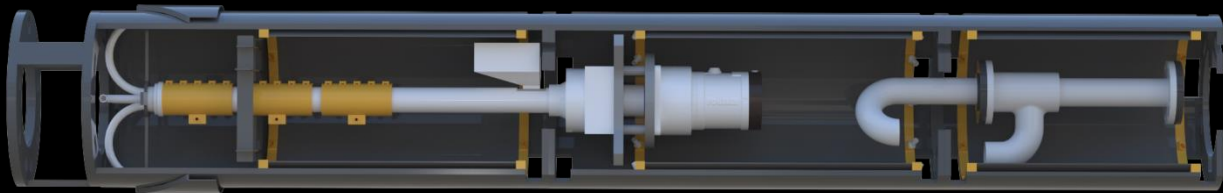

Propulsion

The propulsion mechanism consists of two identical propulsion and bracing units for a total of 16 hydraulic cylinders. Eight cylinders are responsible for the so-called bracing mechanism. When fully extended, four bend steel plates move outwards in radial direction allowing the machine to brace (or grip) against the newly extruded tunnel lining pipe and creating the necessary friction forces to allow propulsion. The remaining eight cylinders allow the machine to be pushed forward with forces up to 200kN. The two units are identical and have been designed to allow continuous digging by operating in a sequential fashion, imitating the motion of a caterpillar.

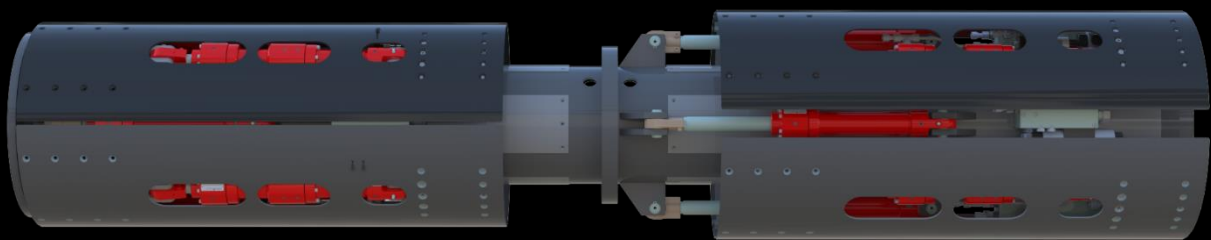

Starting Platform

To avoid the necessity for a starting pit, the MTBM can start digging from the surface thanks to the custom-designed starting platform. The platform allows *Groundhog Beta* to initiate digging operations faster and more efficiently, reducing the use of additional mining material and displacement of soil. The starting platform absorbs the entire driving forces of the TBM and acts as a guide for the machine.

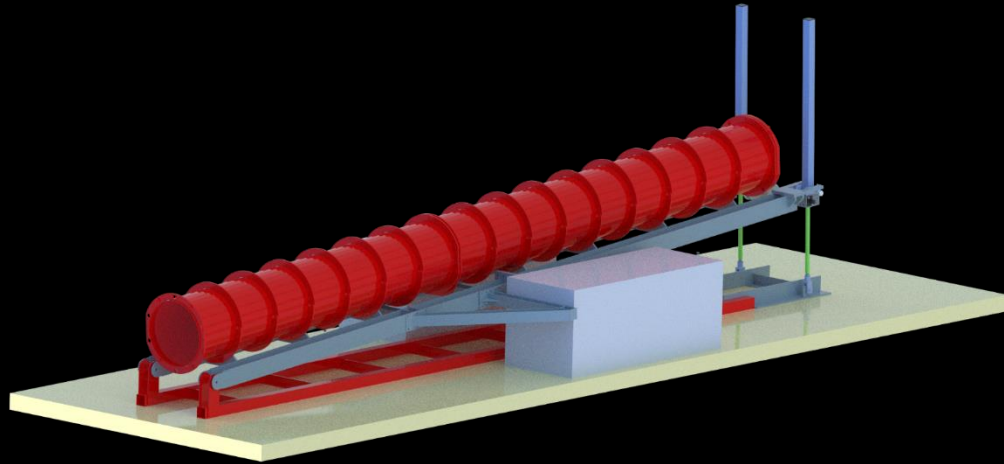

Reach out



Yannick Albrecht

Head of Design & Communication

yannick.albrecht@swisslooptunneling.ch

+41 (0)76 396 05 08



Stefan Kaspar

Founder & Co-President

stefan.kaspar@swisslooptunneling.ch

+41 (0)78 605 71 82